

ARACUS

*The Next Generation -
The proven gold standard Amino Acid Analyser*



**AMINO
ACID ANALYZER**

55 % faster than traditional

44 amino acids in **66** minutes

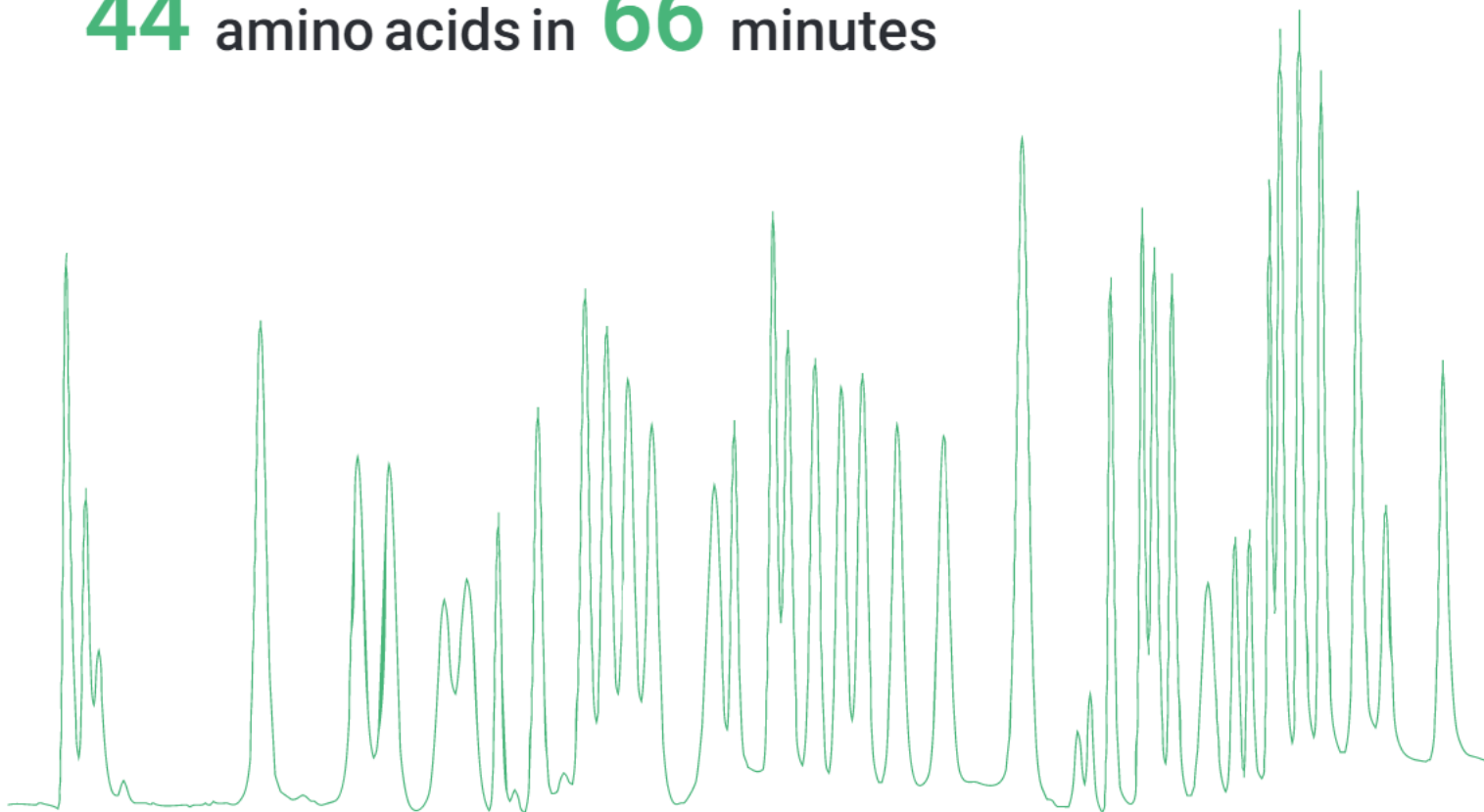



Serie of ARACUS

The serie of ARACUS works according to gold standard of post column derivatization with ninhydrin, with detection at 440 nm and 570 nm using maintenance free LED photometers.

A separation of up to 44 amino acids in about one hour is possible, but also of a few amino acids within a few minutes. The series of ARACUS is used in clinical laboratory (e.g. IVD newborn screening), in quality control for Food, Beverages and Feedstuff and in Research.



2 patents granted

- DE102016010887B3
- DE102018108312A1

IMPROVEMENTS of the Next Generation:

- *All eluents in a separated eluent box to protect from temperature & light*
- *Column oven more protected against external temperature influences*
- *New damping units for improved signal-to-noise ratio*
- *Improved reactor for better separation*
- *New colors for a fresher design*
- *New columns for better and faster separation*
- *New dual photometer with reliable precision & sensitivity (ARACUS lite)*

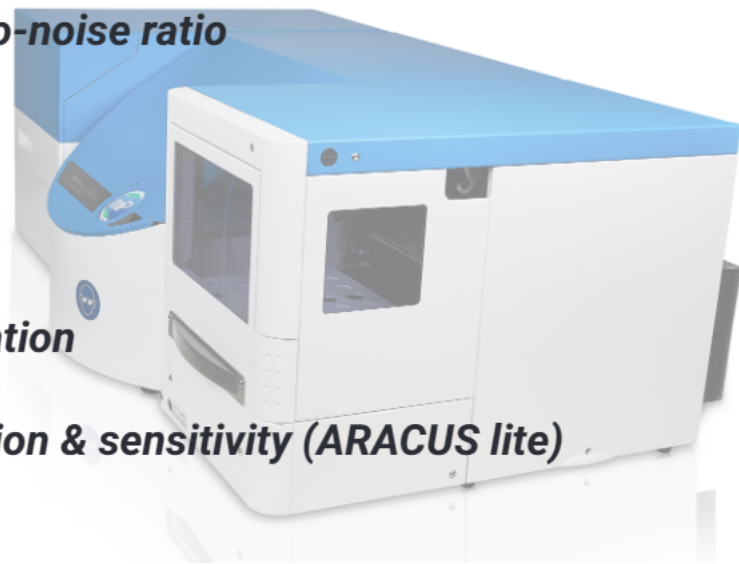

The setup of the ARACUS „classic“ is the standard configuration of the analyzer series. The ARACUS „classic“ allows the continuous analysis of 96 samples in a cooled autosampler. The pump allows the simultaneous operation of two fluidic lines (eluent side and reactive side), which guarantees a constant mixing.

Eluents and reagent solution are selectively chosen through valves and are ideally mixed to each other. The addition of ninhydrin provides a quantitative analysis statement. A washing routine of the injection valve and syringe pump avoids cross contaminations. The level of the individual reagents can be monitored during the runs and warns the user if the quantity is no longer sufficient.

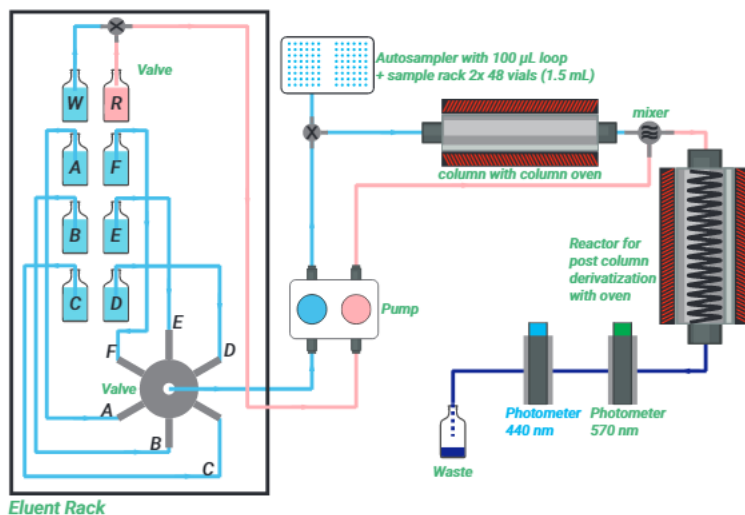

ARACUS „advanced“



The ARACUS „advanced“ is an extended configuration of the ARACUS „classic“ by an additional second pump drive. The upgraded pump configurations allows the independent operation of two fluidic lines (eluent side and reactive side).

The use of two pump drives results in an improved signal-to-noise ratio of the chromatogram.

The freely adjustable parameters between the eluent and the reagent pump drives also provide the possibility of using the reagent OPA (o-phthalaldehyde) for detection of primary amines with a fluorescence detector.

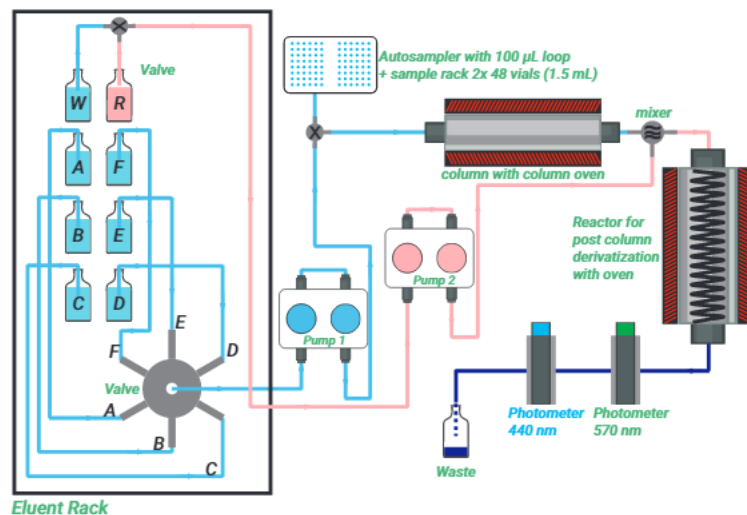

ARACUS „lite“

The ARACUS „lite“ is a simplified configuration of the ARACUS „classic“ and designed for a reduced number of samples and smaller available budget. Due to the small sample throughput and less eluent consumption the bottles of eluents are reduced in size and makes it possible to store the eluent bottles inside of the device and the rack. The „lite“ is using the same pump configuration for operation of two fluidic lines (eluent side and reactive side) and suitable for High Speed and High Resolution columns.

The system equipped with manual injection mode can be connect also with an autosampler like all our devices. The „lite“ comes just with one LED photometer depending on the application. For analysis of 1° amino acids with 570 nm, for 1° and 2° with 500 nm. The system can be upgraded to a dual wavelength photometer with 440 and 570 nm by replacing the already installed photometer.

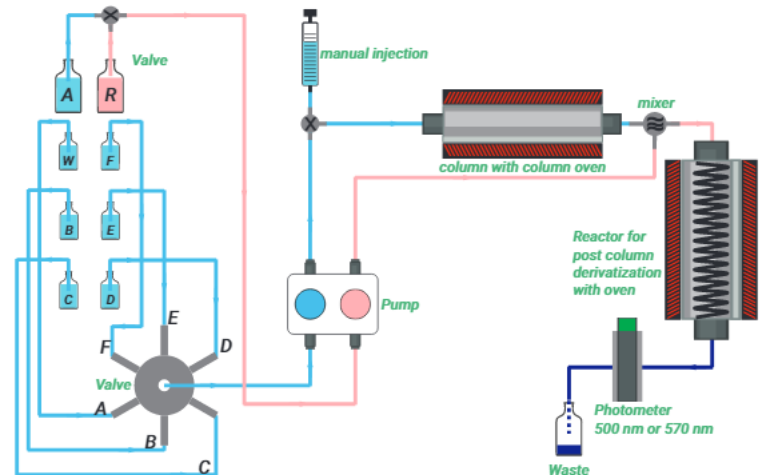

Technical Specifications



AMINO ACID ANALYZER

method	post column derivatization
autosampler	2 racks, each of them with space for 48 vials, sample cooling dosage in 3 different injection modes: full loop (100 μ L), partial loop (5 - 50 μ L), microliter pickup (1 - 27 μ L)
column	stainless steel, cation exchange resin reproducibility of retention time < 0.3 % RSD reproducibility of peak area ~ 1.0 % RSD
column oven	5 - 80 °C, accuracy 0.1 %
reactor temperature	5 - 135 °C
spectroscopic detection	LED photometers (440 nm + 570 nm), 8 years warranty measuring range: high, low flow cell: 10 μ L volume, 3 years warranty

Technical Specifications

detection limit	< 40 pmol* with ninhydrin, < 4 pmol* with OPA method
quantification limit	> 100 pmol* with ninhydrin, > 10 pmol* with OPA method
pump system	single pump (ARACUS), dual pump (ARACUS advanced) max. pressure: 400 bar flow rate: 0.01 - 10.00 mL/min reproducibility of low rate: 0.1 % RSD at 100 µL/min
maximum operating pressure	120 bar/ 1740 PSI (pressure shut off feature)
ready to use kits	kits including eluents, reagent and additional dilution buffer, ammonia adsorber and separation columns for 500 - 1000 runs
control software & Data acquisition	iControl + Clarity (21 CFR Part 11 compliant) or iControl + AminoPeak
dimensions (L X W X H) weight, power	classic/advanced: 1000 x 680 x 360 mm**, 60 kg, 110 - 230 V lite: 1000 x 680 x 360 mm**, 23 kg, 110 - 230 V autosampler: 300 x 590 x 360 mm**, 25 kg, 110 - 230 V

* injection volume = 20 µL ** 780 mm with opened main unit

Applications

Determination of free/ physiological amino acids in blood plasma, serum, saliva and urine

- newborn screening
 - Argininemia (ARG)
 - Arginosuccinic aciduria (ASA)
 - Citrullinemia (CIT)
 - Homocystinuria (HCY)
 - Hyper methioninemia (MET)
 - Maple syrup urine disease (MSUD)
 - Ornithine transcarbamylase deficiency (OTC)
 - Phenylketonuria (PKU)
 - Tyrosinemia (TYR)
- cardiovascular diseases
- Diabetes type II



Determination of biogenic amine for the investigation of metabolic processes

- plant
 - growth factor: Tryptamine
- *animal & human*
 - neurotransmitter: Histamine, Serotonin, Dopamine etc.

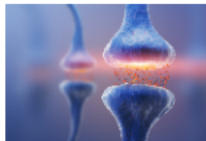

Determination of hydrolysed amino acids in food, beverages and feedstuff

- food
 - meat
 - cheese



- beverages
 - beer
 - milk
 - juice
 - tea
 - wine



- feedstuff
 - fish feed



ARACUS IVD

The ARACUS (classic/advanced) can be used according to CE Regulation IVDR EU 2017/746. In this case a certain eluent kit certified according to IVDD 98/78/EC has to be used.

InVitro diagnostic Kit according to IVDD 98/79/EC

IVD kit for the qualitative and quantitative determination of amino acids in physiological fluids like human blood and urine for medical diagnostics:

- homocystein
- valine
- methionine
- isoleucine
- leucine
- norleucin
- tyrosine
- phenylalanine



There are two variants of the eluent kit IVD:

- AA Eluenten-Kit IVD
- AA Eluenten-Kit IVD advanced

Each kit contains the consumables for analysis of at least 500 runs, performed with a standard program of the ARACUS system. The shelf life of eluents and reagent before opening and activation is 24 months from the date of production.



Options



Manual injection port

upon request each system can be supplied as manual configuration

Software 21 CFR Part 11 compliance

Manual and automatic peak integration with integrated IQ/OQ procedure for software (only available with software Clarity)

Level control

Active control of fluid volume by weight cell of each bottle. (only available with software Aminopeak)



Inert gas

It supplies the main unit and eluent box with a protective gas atmosphere by reducing the presence of atmospheric oxygen to enhance the signal to noise ratio



Prime and Purge Valves

High Pressure side prime and purge valves in eluent and reagent flow

Fluorescence detector

For sensitive fluorescence detection of 1° amines with o-phthalaldehyde (OPA) we are providing the suitable fluorescence detector



AMINO ACID ANALYZER

Separation performance

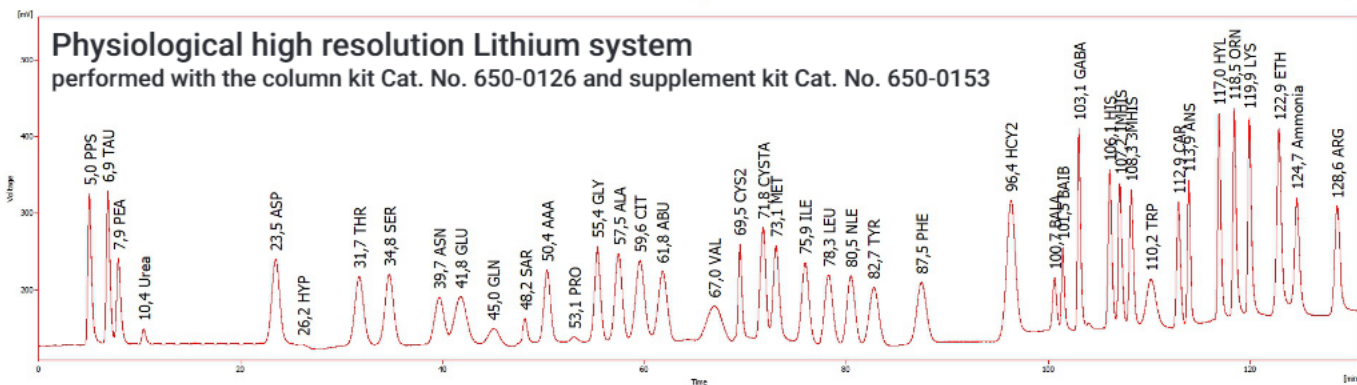
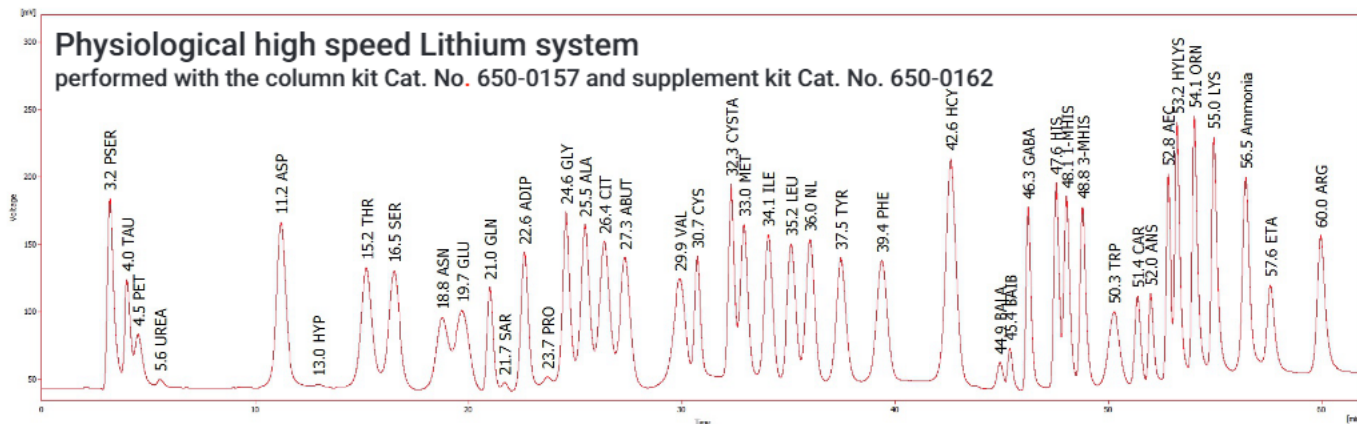

Short programm, analysis of amino acid within 15 min

I & II were performed with the column kit Cat. No. 650-0157 and supplement kit Cat. No. 650-0162

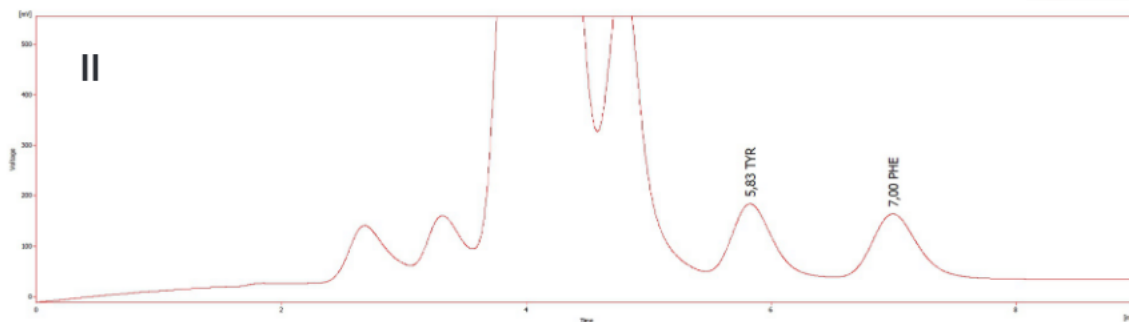
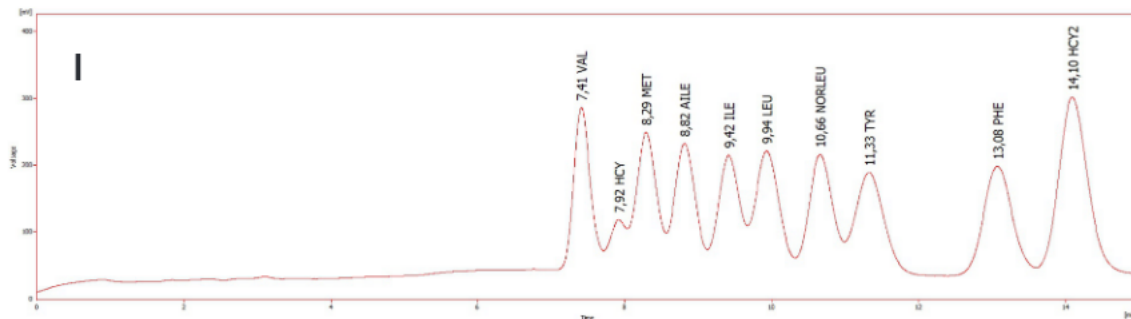

Separation performance

Feedstuff advanced Sodium system

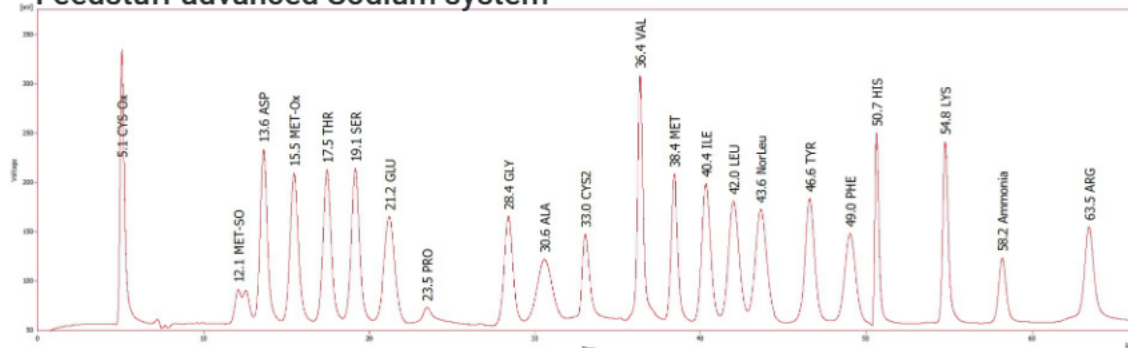

performed with the column kit Cat. No. 650-0165 and supplement kit Cat. No. 650-0167

Feedstuff advanced, Sodium System + amino sugars

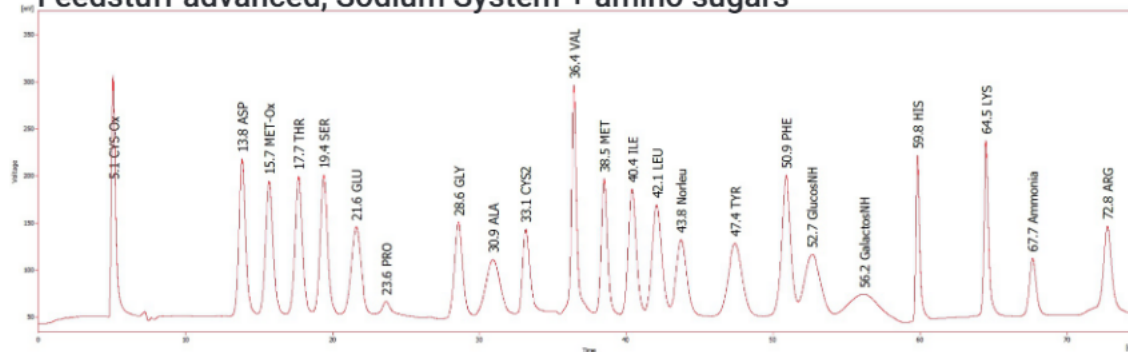

performed with the column kit Cat. No. 650-0165 and supplement kit Cat. No. 650-0167 + Cat. No. 650-0198



AMINO ACID ANALYZER

Separation performance

Hydrolysate Sodium system

performed with the column kit Cat. No. 650-0187 and supplement kit Cat. No. 650-0185

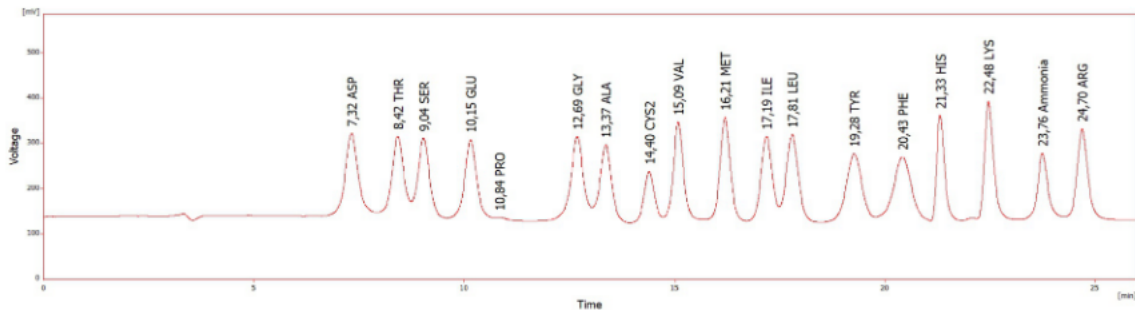

Biogenic Amine Potassium system

performed with the column kit Cat. No. 650-0140 and supplement kit Cat. No. 650-0147

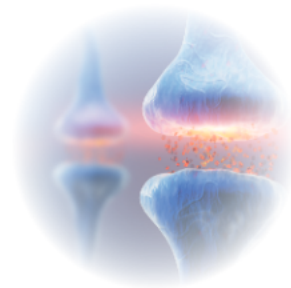
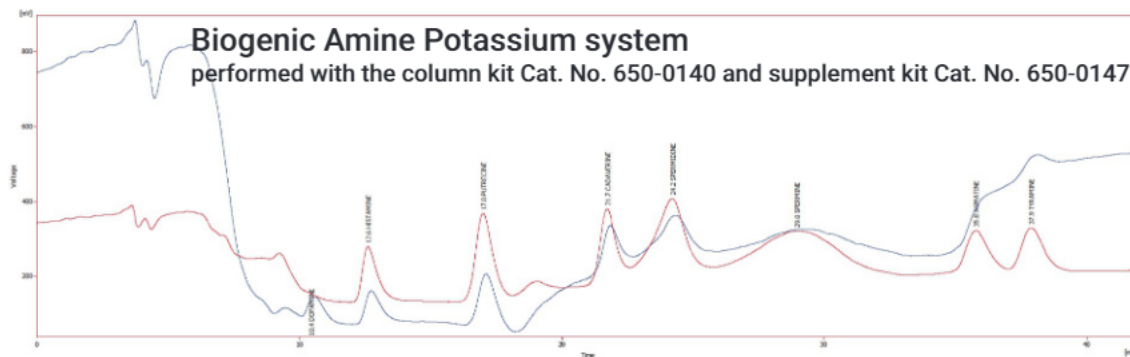

Columns & Supplement Kits

Description	Cat. No.	suitable supplement kit* (Cat. No.)
Lithium High Speed	650-0157	650-0162
Lithium High Resolution	650-0126	650-0153
Lithium Advanced Plus	650-0178	650-0131
Sodium High Speed	650-0187	650-0185
Sodium High Resolution	650-0190	650-0196
Sodium Advanced	650-0165	650-0167
Potassium Biogenic amines	650-0140	650-0147

* each buffer, eluent, columns and reagent can be ordered separately



Consumables

Description	Cat. No.
Standard Physiological (42 amino acids)	650-0035
Standard Hydrolysate (18 amino acids)	650-0036
Standard Feedstuff (20 amino acids)	650-0037
Standard Canonical (20 amino acids)	650-0120
Standard Biogenic Amines (8 amines)	650-0150
Standard Norleucin (<i>internal Standard</i>)	650-0069
sample preparation kit (150 analysis)	650-0022
pre column (ammonia adsorber)	650-0020
AA Eluenten-Kit IVD (CE)	650-0146

Made in Germany, more than 25 years...



membraPure GmbH
Wolfgang-Küntscher-Str. 14,
16761 Hennigsdorf/Berlin, Germany
Tel.: +49 3302 - 201 20 0



info@membrapure.de
www.membrapure.de